

Split Ring Clamp

P/N: 300_02_SRCH

The split ring clamp is used to lock the headform in a particular position and hold it during the impact test. The clamp's weight is customized to your testing setup to help you reach the required total mass assembly required by certain standards.

FEATURES:

- The weight can be customized from 180 grams up to 1200 grams (± 5 grams)
- Made of magnesium, aluminum and brass alloy



Ball Arm

P/N: 230_01_BA

The Cadex ball arm holds the accelerometer and allows the headform to rotate.

FEATURES:

- Available in magnesium, aluminum or stainless steel
- Coming in 20°, 25°, 30° or 35° angles



Ball arm assembled with a split ring clamp

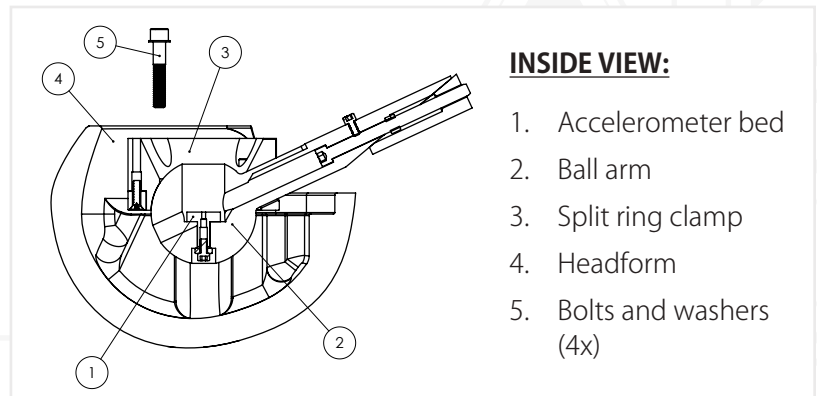

INSIDE VIEW:

1. Accelerometer bed
2. Ball arm
3. Split ring clamp
4. Headform
5. Bolts and washers (4x)